

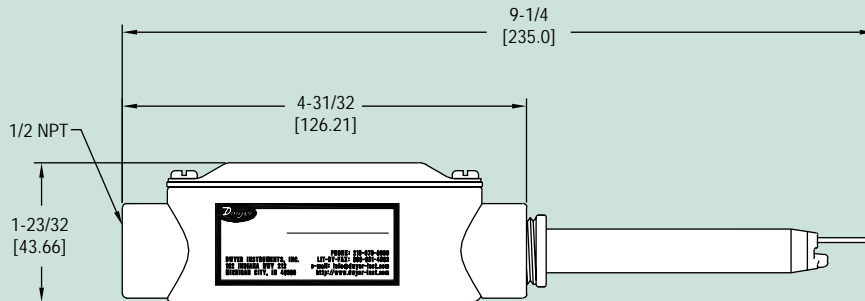

Series
641B

Air Velocity Transmitter

8 Field Selectable Ranges in FPM or MPS



The Series 641B Air Velocity Transmitter uses a heated mass flow sensor technology. It has 4 user-selectable ranges from 250 FPM to 2000 FPM with corresponding metric ranges of 1.25 MPS to 10 MPS. The 641B provides an isolated 4-20 mA output proportional to the velocity.

The Series 641B's steel sensor allows the unit to be used in dirty air environments. This rugged sensor is ideally suited for quick field cleaning from a simple cloth to a pulse of air from an air source. Proper sensor performance can be maintained in these polluted environments by easily removing dust and debris from the sensor which is problematic for pitot tubes and other flow sensing transmitters.

641B-4 Air Velocity Transmitter

Accessories

A-156, Flange Mounting Plate with 1/2" female NPT

A-155, Mounting Gland with 1/2" male NPT fitting

SPECIFICATIONS

Service: Air and compatible, non-combustible gases.

Accuracy:

5% FS Process gas: 32 to 122°F (0 to 50°C).

6% FS Process gas: -40 to 32°F & 122 to 176°F
(-40 to 0°C & 50 to 80°C).

Response Time: Flow: 1.5 seconds to 95% of final value
(Output filter set to minimum).

Temperature Limits: Process: -40 to 176°F (-40 to 80°C).
Ambient: 32 to 140°F (0 to 60°C).

Humidity Limit: Non-condensing.

Power Requirements: 12-35 VDC, 10-16 VAC.

Output Signal: 4-20 mA, isolated 24V source, 3 or 4-wire connection.

Output Filter: Selectable 0.5 -15 (seconds).

Loop Resistance: 600 ohms max.

Current Consumption: 300 mA max*.

Electrical Connections: Screw terminal.

Enclosure Rating: Designed to meet NEMA 4X.

Mounting Orientation: Unit not position sensitive.

Weight: 12.6 oz (357.2 g).

* A brief current transient exceeding 300 mA may be seen on startup.